

SELFOC® MICRO LENS(SML), Standard

There are two categories of lenses, both distinguished by a different numerical aperture: SLW (wide) and SLH (high). Each NA type is appropriate for different applications and exhibits different alignment sensitivities.

While the numerical aperture is a maximum at the center of the lens aperture, the actual NA is a function of the ray parameters (height and angle) for each ray that strikes the lens' Surface (see technical note for detail).

C18 is optimized for Single Mode Fiber application to have better coupling efficiency. So, when you consider the usage of SMF, C18 have better Insertion Loss performance than W18.

Applications:

- Laser diode-to-fiber coupling
- Fiber-to-detector coupling
- Fiber-to-fiber coupling
- Focusing and collimating

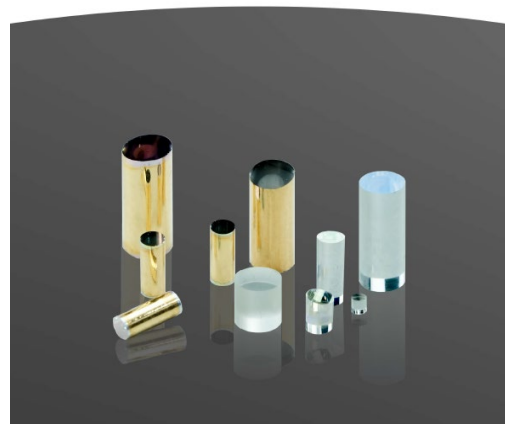

Optical Parameters:

Lens Type		W10	W18	W20	W30	W40	C18	H18	
Diameter		Φ1.0mm	Φ1.8mm	Φ2.0mm	Φ3.0mm	Φ4.0mm	Φ1.8mm	Φ1.8mm	
Wavelength	NA(2θ)	0.46 (55°)						0.60 (74°)	
630nm	N ₀	1.607			1.635		-	1.658	
	√A	0.608	0.339	0.304	0.207	0.154	-	0.430	
	Z @0.25P	2.58mm	4.63mm	5.17mm	7.60mm	10.24mm	-	3.65mm	
830nm	N ₀	1.599			1.625		-	1.646	
	√A	0.601	0.332	0.298	0.203	0.151	-	0.423	
	Z @0.25P	2.61mm	4.73mm	5.27mm	7.75mm	10.43mm	-	3.71mm	
1310nm	N ₀	1.592			1.617		1.592	1.636	
	√A	0.597	0.327	0.295	0.199	0.148	0.324	0.418	
	Z @0.25P	2.63mm	4.80mm	5.32mm	7.87mm	10.59mm	4.85mm	3.76mm	
1550nm	N ₀	1.590			1.615		1.590	1.634	
	√A	0.596	0.326	0.294	0.199	0.148	0.323	0.417	
	Z @0.25P	2.64mm	4.82mm	5.34mm	7.89mm	10.62mm	4.86mm	3.77mm	

NA: Calculated value on axis

N₀: On-axis refractive index / not guaranteed

√A: Index gradient constant nominal value

Z: Lens length with 0.25 pitch at lens center, nominal value



Common Characteristics :

Item	Specification	Notes
Transmittance	89% min.	Wavelength : 380-2000nm, 5mm, uncoated
Polarization Preservation	0.99	Non-stressed state
Effective diameter	Approx. 60-70% of lens Diameter	
Index Gradient Constant \sqrt{A} Tolerance	$\pm 2.5\%$ max.	Between ion exchange batches
	$\pm 0.75\%$ max.	Within same ion exchange batch
Lens Diameter Tolerance	+0.005/-0.01mm	For all SMLs except SLW3.0 and 4.0
	+0/-0.02mm	For SLW-3.0 and SLW-4.0
Lens Length Tolerance	+0/-0.04mm	Machining and polishing tolerance
End Facet Perpendicularity	6 mrad. max.	
Ellipticity	3um	Dmax-Dmin
Glass Material	Oxide Glass	
Young's Modulus	6000 - 8000 Kgf/mm ²	Typical
Thermal Expansion Coefficient	$10 \times 10^{-6}/^{\circ}\text{C}$	Typical

Surface Quality (inspected at x20 mag.) :

Item	Specification
Pinholes / Particles	Defects greater than 30um in diameter are not allowed. Defects smaller than 10um in diameter are allowed. Up to three defects with diameter between 10um and 30um are allowed.
Scratches	Scratches wider than 5um are not allowed. Scratches narrower than 2u are allowed. Up to three scratches with 5um max. width and 200um max. length are allowed.
Chippings	Chippings are not allowed within the concentric area of 90% of the lens diameter.

Options :

Metallization

Metallization of the side surface allows the user to solder the lens into a housing. The purpose is to create a hermetic seal and to provide greater bonding strength than epoxy bonding.

We have 2types of Metallization, one is M-Meta that is good for Pb/SN solder(relatively old solder) and other is U-Meta that is good for Au/Sn solder(high temperature).

Item / Type	M-Type	U-Type
Application	Pb/Sn Solder	Au/Sn Solder
Configuration	Cr : $500 \pm 150\text{\AA}$	Ti : $1000 \pm 200\text{\AA}$
	Pt : $500 \pm 150\text{\AA}$	Pt : $1500 \pm 200\text{\AA}$
	Au : $6000 \pm 1000\text{\AA}$	Au : $5000 \pm 1000\text{\AA}$
Max. Solder Temperature	230°C x 10sec	380°C x 120sec (in Nitrogen)

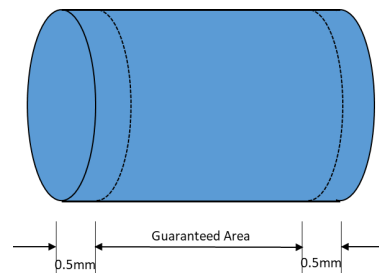

AR Coating

AR coating reduce the amount of light lost due to Fresnel reflection at the lens surfaces. They also help to protect the lens surfaces from humidity, chemical reaction, and physical damage. Five grades of coating(S, K, U, H, D) are available, each with its unique characteristics. The coating are optimized for specific wavelength(s).

Item / Coating Type	None-Coated	S-Grade		U-Grade	K-Grade	D-Grade	H-Grade
Wavelength range	-	630nm ± 15nm 830nm ± 15nm	1310nm ± 30nm 1550nm ± 30nm	600 ± 200nm	1400 ± 200nm	830 ± 15nm & 1310 ± 30nm	980 ± 30nm & 1550 ± 30nm
Maximum Reflection per surface	4 ~ 6%	0.25%		1.50%	0.20%	0.50%	
Coating Structure	Multilayer Metal Oxide						
Maximum Temperature	350°C	200°C x1000hrs					
Maximum Humidity and Reliability	Not recommended for high humidity	85°C/85%RH 1000hrs					

Typical AR Spectrum

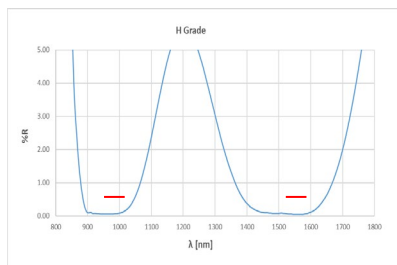
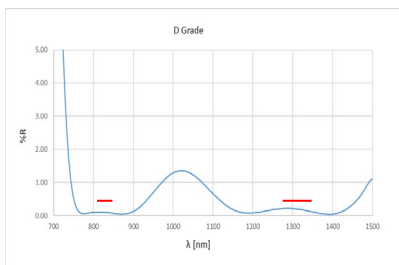
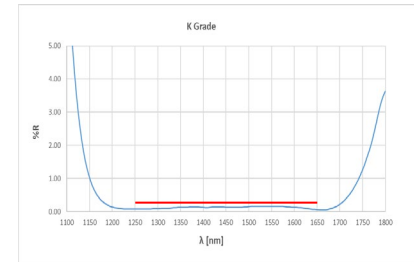
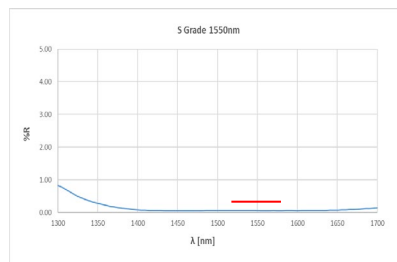
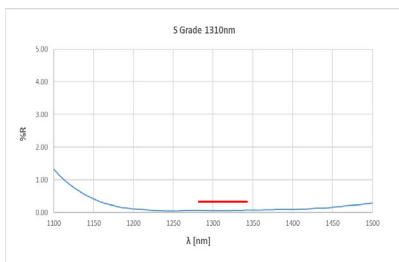
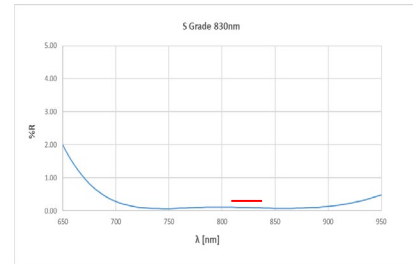
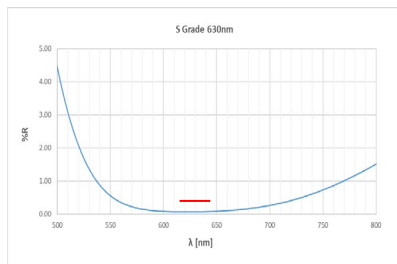
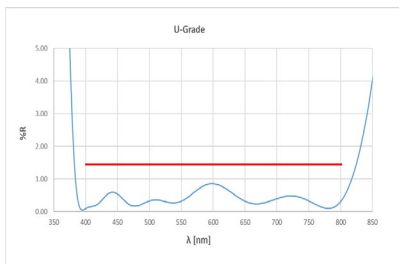

Angled Facet

Angling one or more of the lens facets can effectively reduce back reflection from the surface(s). This option is available for all SELFOC Microlens (SML) with OD of 1.0, 1.8 and 2.0mm. There are two types of angled facets available. With the Single-Angle option, one lens facet is tilted while the other remains perpendicular to the optical axis. With the Double-Angle Option, we can offer 'Parallelogram' that is both facets are tilted identically such that they remain parallel to each other and 'Trapezoid' that is

- . Back reflection can be further minimized with the use of AR coating.

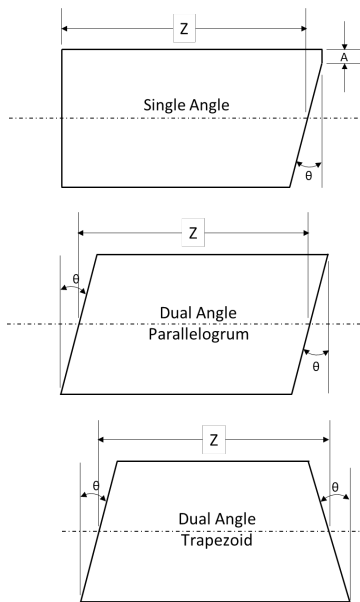

Ordering Guide:



SML Type Side Coating Lens Type Lens Diameter Variable Pitch Variable Cutting Wavelength Side A Side B AR Coating Angle A Angle B Shape

SML TYPE	
Code	Code Description
P	Plano
X	Angled

Side Coating	
Code	Code Description
N	No Coating
U	U-Metallization
M	M-Metallization

Lens Type	
Code	Code Description
C	C-Type
W	W-Type
H	H-Type

Lens Diameter	
Code	Code Description
10	1.0 mm
18	1.8 mm
20	2.0 mm
30	3.0 mm
40	4.0 mm

Variable Pitch	
Code	Code Description
S	Maximum Root A
4 Numeric Value of the Pitch, format follows sample below:	
Sample Code	Code Description
0250	0.250 Pitch
0245	0.245 Pitch

Variable Cutting Wavelength	
3 Numeric Value of the Cutting Wavelength.	
Format follows sample below:	
Sample Code	Code Description
063	630 nm
083	830 nm
131	1310 nm
155	1550 nm

AR Coating Type	
Code	Code Description
0	630 nm
3	830 nm
7	1310 nm
8	1550 nm
N	Not Applicable

Lens Angle	
Code	Code Description
0	Flat
8	8°

Angle Shape	
Code	Code Description
T	Trapezoid
P	Parallel

AR COATING			
Code	Center Wavelength	Range	Optical Performance (Each Side)
K	1450 nm	±200	R ≤ 0.20 %
	630 nm	±15	R ≤ 0.25 %
	830 nm	±15	R ≤ 0.25 %
	1310 nm	±40	R ≤ 0.25 %
S	1550 nm	±40	R ≤ 0.25 %
	830/1310 nm	±15/±30	R ≤ 0.50 %
H	980/1550 nm	±30	R ≤ 0.50 %
U	600 nm	±200	R ≤ 1.50 %
P	Passivation Coating		
N	NON COAT		

